

barbas .

Installation and user manual

Barbas Wi-Fi Box 3



Barbas Gas Fireplace App

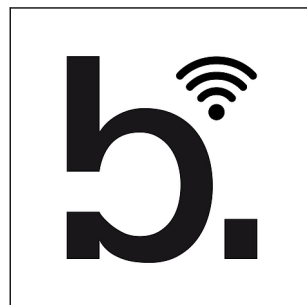

© **Barbas BV**

This document or parts thereof may not be reproduced, stored in a retrieval system, or transmitted, in any form or by any means, electronic, mechanical, photocopying, recording, nor otherwise, without the prior written permission of Barbas BV. This document could contain technical inaccuracies or typographical errors. Barbas BV reserves the right to revise this document from time to time in the contents thereof.

Contact information

Barbas BV

Hallenstraat 17, 5531 AB Bladel, The Netherlands

E-mail: info@barbas.com

www.barbas.com

Contents

1	About this document.....	5
2	How to work with this document.....	6
2.1	Warnings and cautions used in this document.....	6
2.2	Related documentation.....	6
3	Description.....	7
3.1	Intended use.....	7
3.2	Overview Barbas Wi-Fi Box 3	7
3.3	LED indication	8
4	Requirements.....	9
4.1	Wi-Fi router.....	9
4.2	Receiver.....	9
4.3	Handset	9
4.4	Mobile device.....	9
5	Installation Wi-Fi Box 3.....	10
6	Description app symbols.....	11
6.1	Symbols - General.....	11
6.2	Symbols - Warnings.....	11
6.3	Symbols - Menu.....	12
6.4	Symbols - Settings.....	12
6.5	Symbols - Operating options.....	13
7	Initial app setup	14
7.1	Download the Barbas app.....	15
7.2	Wi-Fi.....	15
7.3	Permissions.....	16
7.4	Choose language and permissions.....	16
7.5	Terms and conditions.....	17
7.6	Add fireplace.....	17
7.7	Add Barbas Wi-Fi Box of the gas fireplace.....	18
7.8	Setup.....	23
7.9	App settings - Set Temperature and Time.....	24
7.10	Add an extra gas fireplace.....	25
7.11	Delete a gas fireplace.....	25
7.12	Appliance settings.....	26

8 Operating the fireplace.....29

- 8.1 ON / OFF..... 30
- 8.2 Manual mode..... 32
- 8.3 Program mode..... 33
- 8.4 Thermostat mode..... 34
- 8.5 ECO mode..... 34
- 8.6 Light..... 35
- 8.7 Fan..... 35
- 8.8 Timer..... 36
- 8.9 2nd burner..... 36

9 Support..... 37

10 Frequent questions..... 38

11 Troubleshooting..... 39

- 11.1 Possible problems and solutions..... 39
- 11.2 Error codes..... 41
- 11.3 Reset of the Barbas Wi-Fi Box 3..... 45

12 Technical data..... 46

13 Warranty Terms..... 47

1 About this document

This document shows the necessary information to do these tasks on the Barbas Wi-Fi Box 3 in combination with the Barbas Gas Fireplace App:

- Installation
- Operation

This document is an essential part of your appliance. Read it carefully before you do work on the appliance. Keep it in a safe place.

The original instructions of the document are in English. All other language versions of the document are translations of the original instructions. It is not always possible to provide a detailed illustration of every single item of the equipment. The illustrations are for instructional use only. Screenshots of the Barbas Gas Fireplace App are from a smart phone. The screenshots of the Barbas Gas Fireplace App on other mobile devices can be different.

2 How to work with this document

1. Make yourself familiar with the structure and content of the document.
2. Make sure that you understand all the instructions.
3. Do the procedures completely and in the given sequence.

2.1 Warnings and cautions used in this document

Warning



If you do not obey these instructions, there is a risk that can cause personal injury or death.

Caution

If you do not obey these instructions, there is a risk of damage to the appliance, installation or to property.

Note

A note shows more information.

Symbol	Description
	Visual sign that there is a hazard
	Visual sign that there is a notice

2.2 Related documentation

All documents that belongs to the Barbas gas appliance.

- Instruction book
- Preparation manual
- Installation and maintenance manual
- User manual
- Assembly instructions for concentric flue system

3 Description

3.1 Intended use

The Barbas Wi-Fi Box 3 is intended for indoor use in combination with a Barbas or Bellfires gas appliance and with the Barbas Gas Fireplace App in combination with a hand set. Do not use it for other purposes.

3.2 Overview Barbas Wi-Fi Box 3

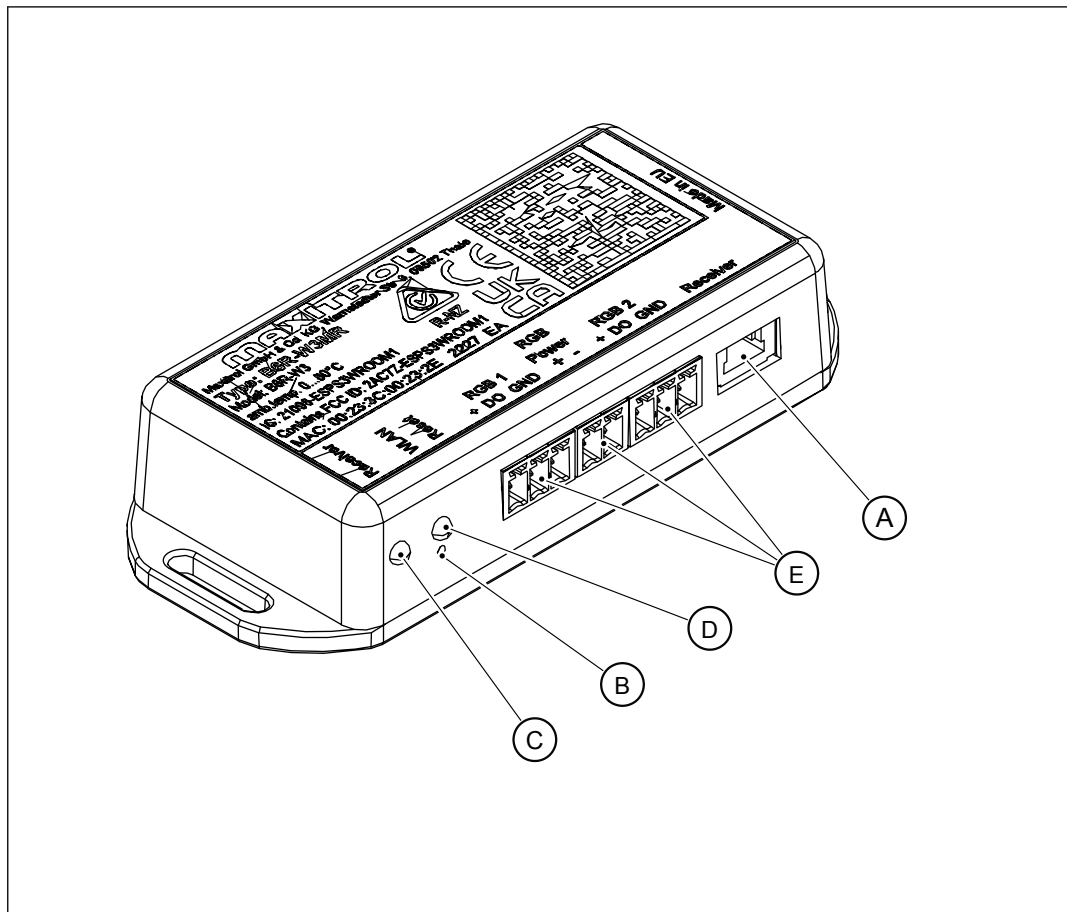

	Item	Description
A	Connector	Connector for the cable to the receiver
B	Reset button	Reset of the Barbas Wi-Fi Box 3. Use paper clip to push button.
C	LED 1	Shows the status of the connection to the receiver
D	LED 2	Shows the status of the Wi-Fi connection
E	RGB 1-3	LED connections. Not in use



Warning: The Barbas gas appliances do not support internal LED lighting. It is not allowed to install any kind of LED lights in the appliance. Failing to do so can cause damage to the appliance.

3.3 LED indication

The Barbas Wi-Fi Box 3 has two LED's with colors red/green/blue.

	Item	Description
LED 1	Green	Connected to receiver
	Red	Not connected to receiver
	Off	Standby mode is active. No power supply
LED 2	Green	Connected to the home network (router)
	Blue/Green blinking	A Wi-Fi network has been detected
	Red	Not connected to the home network (router)
	Off	Standby mode is active or no power supply

4 Requirements

4.1 Wi-Fi router

Minimum requirements Wi-Fi router:

- Compatible with IEEE 802.11n/g/b
- WPA2 encryption
- Radio frequency: 2.4 GHz
- Wireless auto channel: Automated search for Wi-Fi radio channel free of interference
- Support of the User Datagram Protocol (UDP)
- Connection to mDNS is required to make sure Easy Commission Process works.

If the Wi-Fi router is part of a business network, or if the router is applicable for use in a business network, the User Datagram Protocol (UDP) and/or broadcasting must be enabled. Refer to the manual of the router.



Note:

At the end of the installation procedure, the initial router settings can be restored, if necessary.

4.2 Receiver

- Maxitrol (Symax-2) receiver. This type can be recognized by a blue or white sticker attached to it. Contact your dealer if you have a receiver with a green sticker (Symax-1) or a silver sticker (GV60).
- The Maxitrol (Symax-2) receiver is powered (6 VDC) by the Maxitrol light/fan V-module. Use a Maxitrol 6 VDC mains adapter if there is no V-module in the appliance.
- The Maxitrol (Symax-2) receiver supplies the power (6VDC) to the Barbas Wi-Fi Box 3.
- Batteries in the receiver are not sufficient to power the Barbas Wi-Fi Box 3.

4.3 Handset

The Barbas Wi-Fi Box 3 works only with the Maxitrol (Symax-2) 8-button or 10-button handset with a blue or white sticker attached to it.

Contact your dealer if you have a handset with a black sticker (Symax-1) or with a silver sticker (GV60).

4.4 Mobile device







- Tablet or smartphone with IOS 10.0 / Android 10.0 or higher.
- Activated Wi-Fi connection.
- Activated bluetooth connection.

5 Installation Wi-Fi Box 3



1. Make sure you have a Maxitrol (Symax-2) receiver and a Maxitrol (Symax-2) handset (8 or 10 buttons). Both can be recognized by the blue or white sticker. If not, contact your dealer.
2. Connect the 4-wire cable on the connector marked '**SI**' on the receiver.
3. Connect the other side of the 4-wire cable on the connector marked '**receiver**' on the Barbas Wi-Fi Box 3
4. Make sure LED 1 is green. If not, check the connection to the receiver.

6 Description app symbols



6.1 Symbols - General

Symbol	Function	Description
	Home	Goes to the home screen of the appliance(s).
	Settings	Goes to setting menu: <ul style="list-style-type: none"> • Name & Icon • Feature visibility • System information
	Support	Goes to support: <ul style="list-style-type: none"> • Support pages with information about the operating functions. • Contact information
	Menu	Goes to menu: <ul style="list-style-type: none"> • Adding or deleting an appliance to the app • Temperature unit and Time indication
	ON / OFF	Start or stop the appliance.
	Power	Starts or stops the operating functions: <ul style="list-style-type: none"> • Light (when present) • Set programs
	Activate / Deactivate	Activates or deactivates the operating functions .



6.2 Symbols - Warnings

Symbol	Function	Description
	Error message	An error has been detected. It is not possible continue with the configuration. Solve the problem as indicated in the pop-up screen.
	Error message	An error has been detected in the operation of the gas fireplace. Solve the problem as indicated in the pop-up screen.
	Caution	An overlap has been detected in the week program. Make sure that there are no overlaps in any of the setted programs.









6.3 Symbols - Menu

Symbol	Function	Description
	Add device	To add an extra Barbas gas fireplace (device) to the app home screen. Up to 8 fireplaces can be added. All added fireplaces have the same function options.
	Delete device	To delete a gas fireplace from the app home screen.
	App settings	To set: <ul style="list-style-type: none"> • Temperature unit °C. or °F. • Time indication 24h or 12h • Language

6.4 Symbols - Settings

Symbol	Function	Description
	Name & Icon	Shows the name and Icon of the gas fireplace. Here you can also change the name and icon of the fireplace.
	Feature visibility	Shows the functions visible on the app control screen for the fireplace.
	System information	Shows the <ul style="list-style-type: none"> • Signal strength (Router / Wi-Fi Box) • Wi-Fi Box version • Receiver version • Handset version • App version • Date & Time

6.5 Symbols - Operating options

Symbol	Function	Description
	Manual mode	Manual adjustment of the flame height.
	Program mode	Set time and temperature in maximum 8 user defined programs.
	Thermostatic mode	Automatic adjustment of the heat output based on the set room temperature and the measured room temperature.
	ECO mode	Varies the flame height automatically according one of the three available pre-set cycles. The maximum room temperature can be set as desired.
	Light (optional)	Operation of the (optional) lights
	Fan (optional)	Operation of the (optional) convection ventilator.
	Timer	Setting of the time duration before the appliance switches to OFF.
	2nd burner (AUX) feature	Switch between single or double burner (only for appliance with a double burner).

7 Initial app setup



Note: Screen shots shown in this manual are for a smart phone. The Barbas Gas Fireplace App screen on another mobile device can look different on details. The functionality and use is the same as described in this manual.



Note: Make sure:

- Home network is available.
- SSID of the Wi-Fi router is not hidden.
- Home network Wi-Fi signal is in range.
- Wi-Fi router supports the Use Datagram Protocol (UDP).



Note: Make sure:

- the Barbas Wi-Fi Box 3 is connected to the receiver and LED 1 is green.
- Wi-Fi and Bluetooth are turned ON in settings of your mobile device
- you have the SSID name and password of your Wi-Fi router. They are usually shown on a sticker on the router.

Do all procedures in this section.

7.1 Download the Barbas app

To download the Barbas Gas Fireplace App search for "**Barbas**" at the Apple App Store or at Google Play.



7.2 Wi-Fi

Make sure your home network Wi-Fi is connected with your mobile device **BEFORE** starting the Barbas Gas Fireplace App.



7.3 Permissions

1. Start the Barbas Gas Fireplace App.
2. Touch "Allow" button to connect to bluetooth devices.
3. Touch "Allow Once" or "Allow While Using App", button to grant location permission to find the SSID name of the home Wi-Fi router.



7.4 Choose language and permissions

1. Choose language.
2. Touch "Next" button to continue.
3. Choose Permissions.
4. Touch "Next" button to continue.



7.5 Terms and conditions

1. Read terms and conditions.
2. Touch "Accept" button to continue.

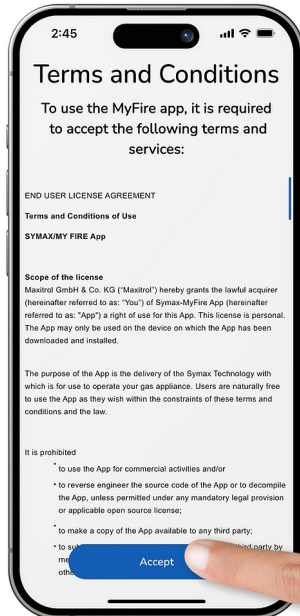

7.6 Add fireplace

1. Touch "Add fireplace" button to continue.

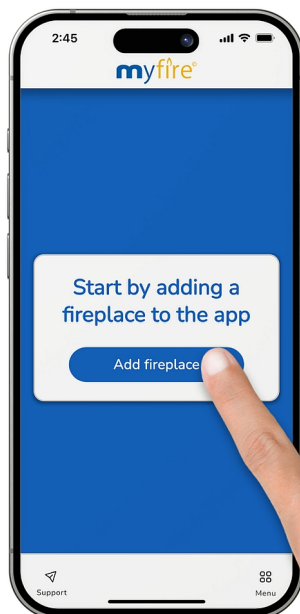

7.7 Add Barbas Wi-Fi Box of the gas fireplace

Make sure the Wi-Fi box is properly installed in the gas fireplace.



Note:

Be aware that various Barbas Wi-Fi Box models have been used in recent years. Depending on the Barbas Wi-Fi box model, there's a specific connection process.

Look on the Wi-Fi Box for the type description.

Model Barbas Wi-Fi Box	Type de- scription Maxitrol	Production Years	App - Wi-Fi - Wi-Fi Box Connection process
Barbas Wi-Fi Box 3 (V3)	B6R-W3BE	2023 -	Connection process V3
Barbas Wi-Fi Box 2 (V2)	B6R-W2BE	2019 - 2023	Connection process V1/V2
Barbas Wi-Fi Box (1) (V1)	B6R-WBE	2017 - 2019	Connection process V1/V2

Connection process Barbas Wi-Fi Box 3 (B6R-W3BE)(V3)

1. Touch “Allow” button to find devices on local networks.
2. Touch the “📶 / +” button to connect to the gas fireplace if you have a Wi-Fi Box 3.



Note: This network cannot be a guest network or a network with blocking policies.

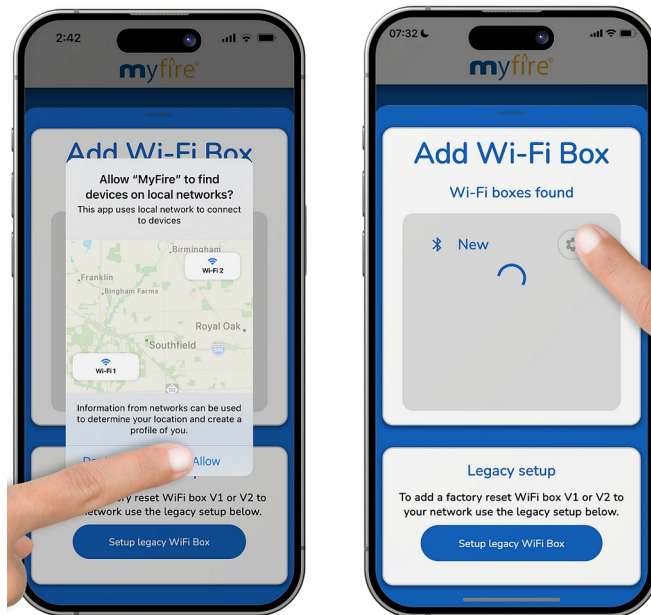

1. Touch the “Enter your Wi-Fi password” button.
2. Enter your Home network password.
3. After you have entered your Home network, touch the “Next” button.
4. Once your connection is successful, touch the “Next” button.

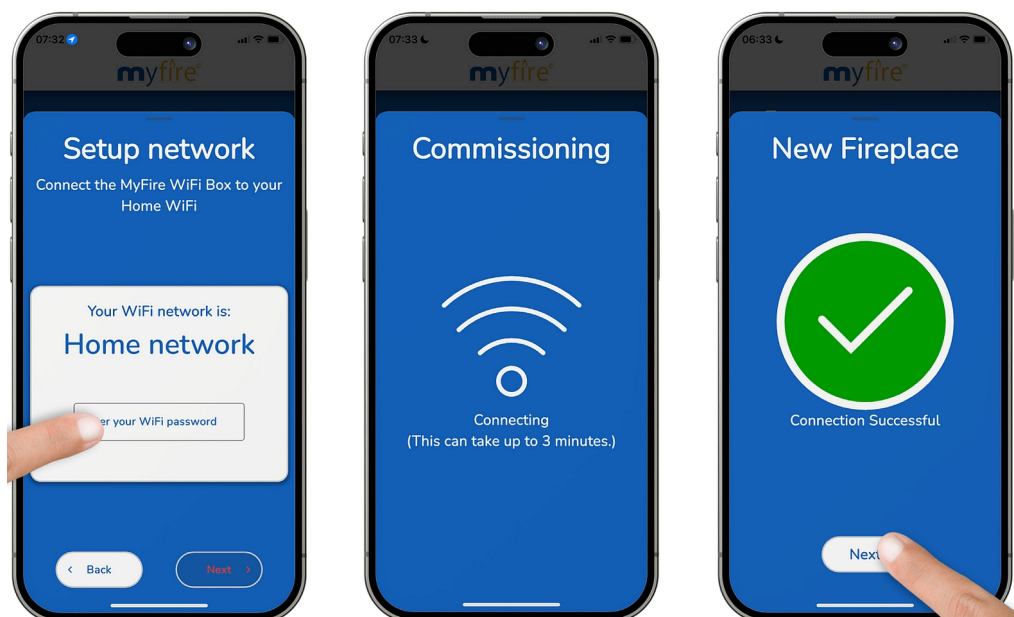

Connection process Barbas Wi-Fi Box 1 & 2 ((B6R-WBE)(V1) and (B6R-W2BE)(V2))

1. Touch "Allow" button to find devices on local networks.
2. If you have a Wi-Fi Box (1) (V1) or Wi-Fi Box 2 (V2), touch "Setup Legacy WiFi Box" button.



1. Touch the "Enter your Wi-Fi password" button to enter your Wi-Fi password.
2. Enter your Home network password.
3. Touch the "Next" button to connect to your Home network.

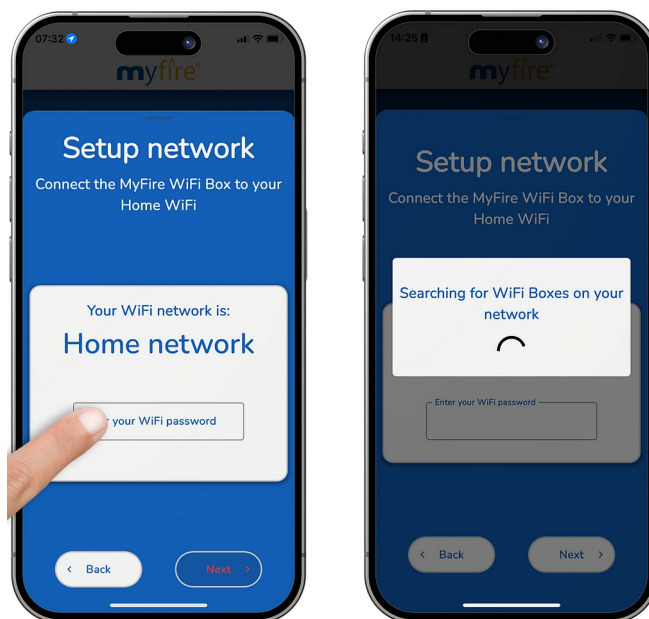

1. Leave the app and go to the Wi-Fi settings on your phone.
2. Connect to the Wi-Fi Box.

Network name: "myfire_WiFi-Box_<number>"

Password: MYFIREPLACE

3. Once you are connected to the Wi-Fi, go back to the myFire app.



Note: Connecting to the Wi-Fi could take up to 3 minutes.

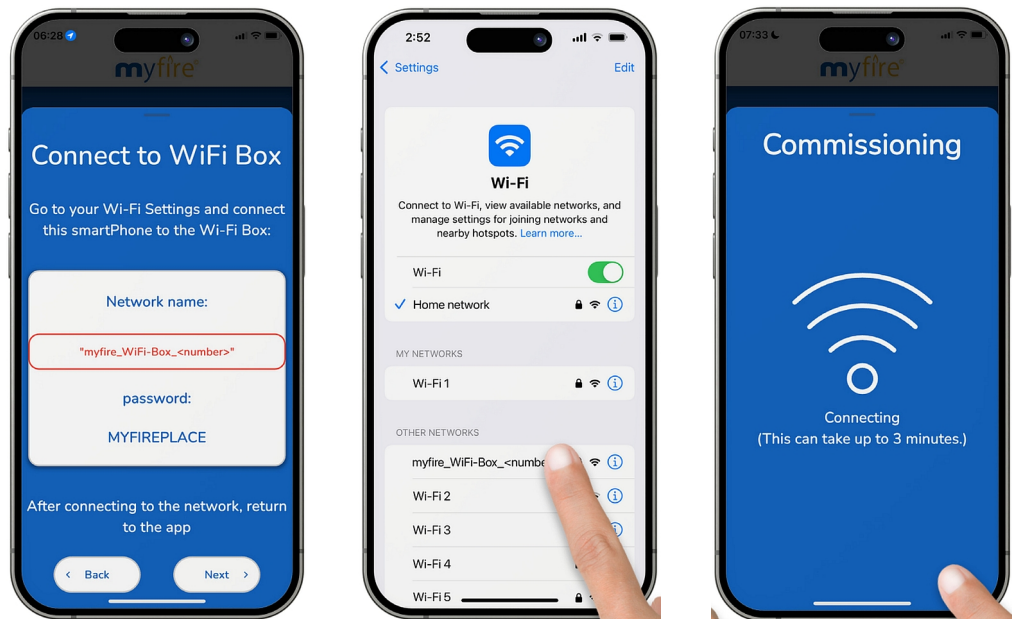

If the smart device does not automatically connect to the home network:

1. Touch the “Home network” button.
2. Connect to the Home network.



Note: It may take a few minutes to connect.



Note: This network cannot be a guest network or a network with blocking policies.

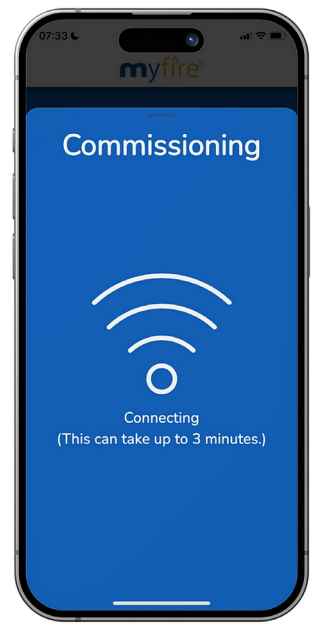
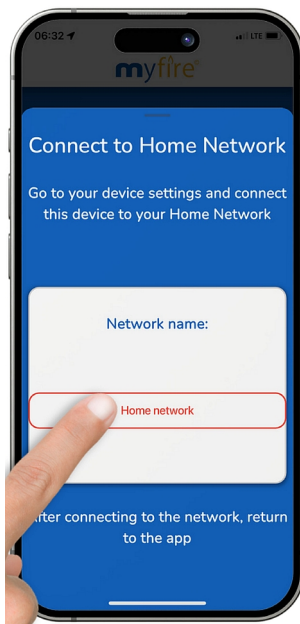

1. Once your connection is successful, touch the “Next” button.

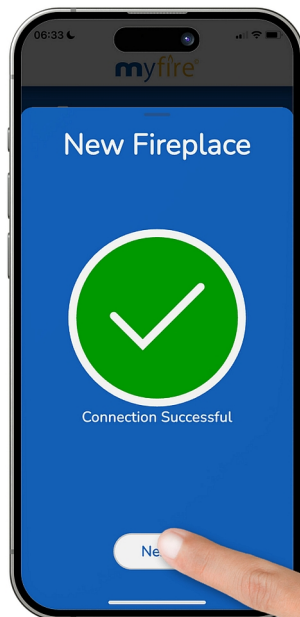

7.8 Setup

1. Touch the “Fireplace Name” button to change the name of the fireplace.
2. Touch an icon that corresponds with the Fireplace Name.
3. Once you are done, touch the “Next” button.

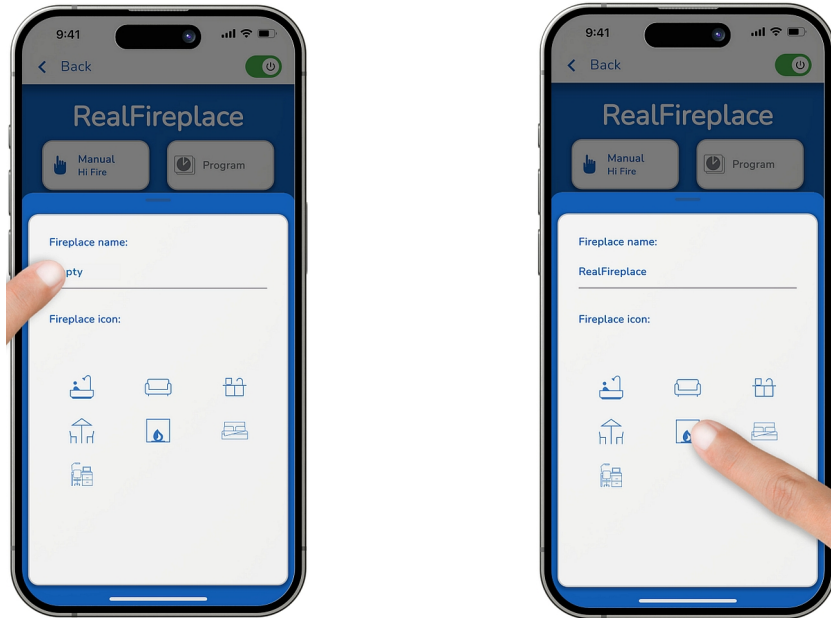

1. Choose the Functions that fit your fireplace; Light, 2nd Burner, Timer, Fan (when present in the fireplace).
2. Once you are done, touch the “Finish” button.



Note: The functions LED1 and LED2 are not in use.



Congratulations :

The Barbas Gas Fireplace App is ready to go and the home screen is displayed.

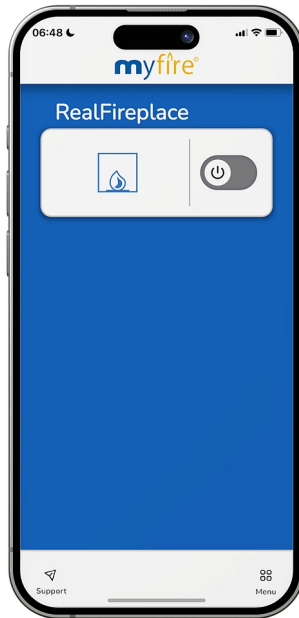
**7.9****App settings - Set Temperature and Time**

1. Touch "Menu" button.
2. Touch "App Settings" button.
3. Choose temperature unit °C or °F.
4. Choose Time indication 24h or 12h.



7.10 Add an extra gas fireplace

1. Touch "Menu" button.
2. Touch "Add device" button.
3. Touch "+" button to add the extra gas fireplace once it appears on the screen.

Repeat the above steps for each extra gas fireplace. Maximum 8 gas fireplaces can be connected.

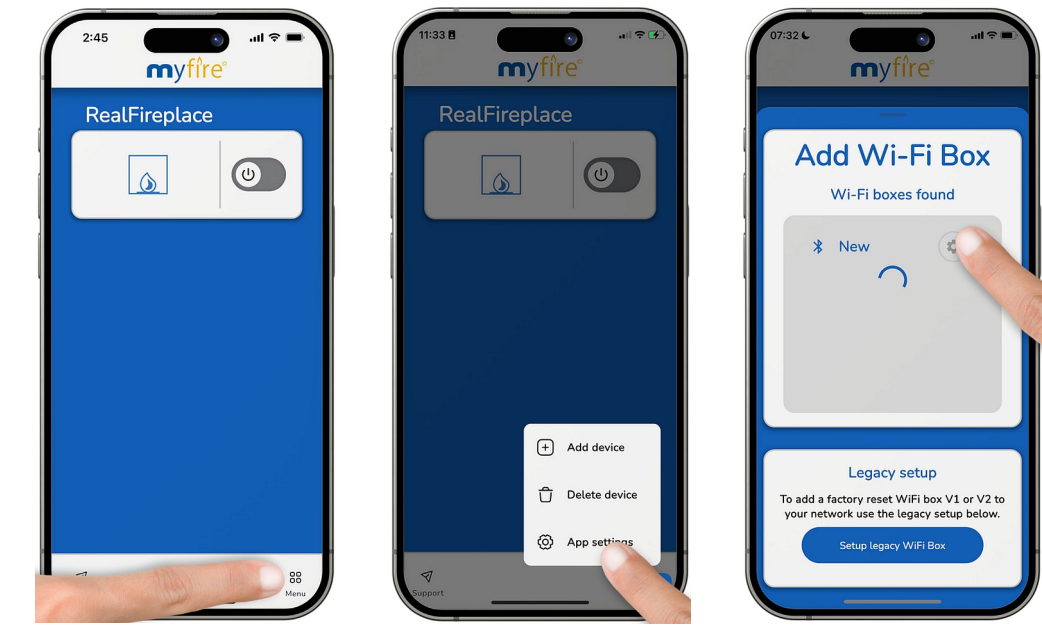

7.11 Delete a gas fireplace

1. Touch "Menu" button.
2. Touch "Delete device" button.
3. Touch "Trash can" button of the gas fireplace you want to remove from the screen.

7.12 Appliance settings

Turn fireplace ON

1. The smart device is now connected to the fireplace.
2. Slide "ON/OFF" button to right to turn ON fireplace.
3. Touch "OK" button for ignition.
4. After successful ignition, Touch the icon to set features.



Note: The total sequence from start to ignition of the burner will take about 20 seconds.

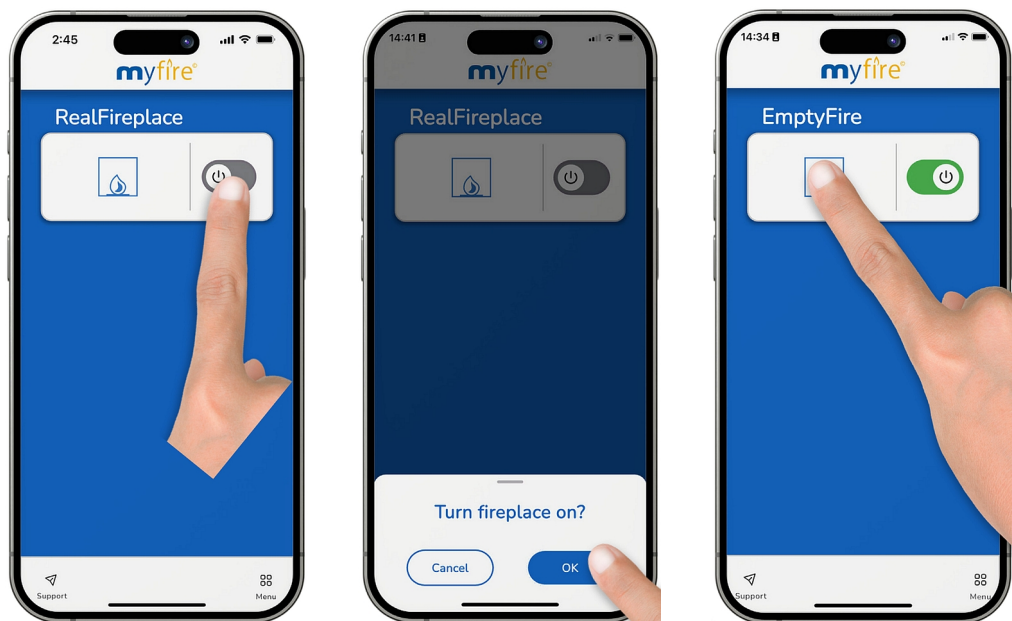

Home screen

Set feature visibility

1. Touch “Settings” button.
2. Touch “Feature Visibility” button.
3. Choose the Functions that fit your fireplace. (Once they are chosen, they will appear on the control screen.)
 - Light
 - 2nd Burner
 - Timer
 - Fan (when present in the fireplace)



Note: The functions LED1 and LED2 are not in use.



Control screen

Set name and icons

1. Touch "Settings" button.
2. Touch "Name & Icon" button.
3. Touch current name to change the name of the fireplace.
4. Touch the desired fireplace icon to match the name of the fireplace.



Control screen

System information

1. Touch "Settings" button.
2. Touch "System information" button.
3. Touch "🔄" button to synchronize the date and clock time.

This screen show's information about the:

- Signal strength (Router / Wi-Fi Box)
- Wi-Fi Box version
- Receiver version
- Handset version
- App version
- Date & Time

8 Operating the fireplace

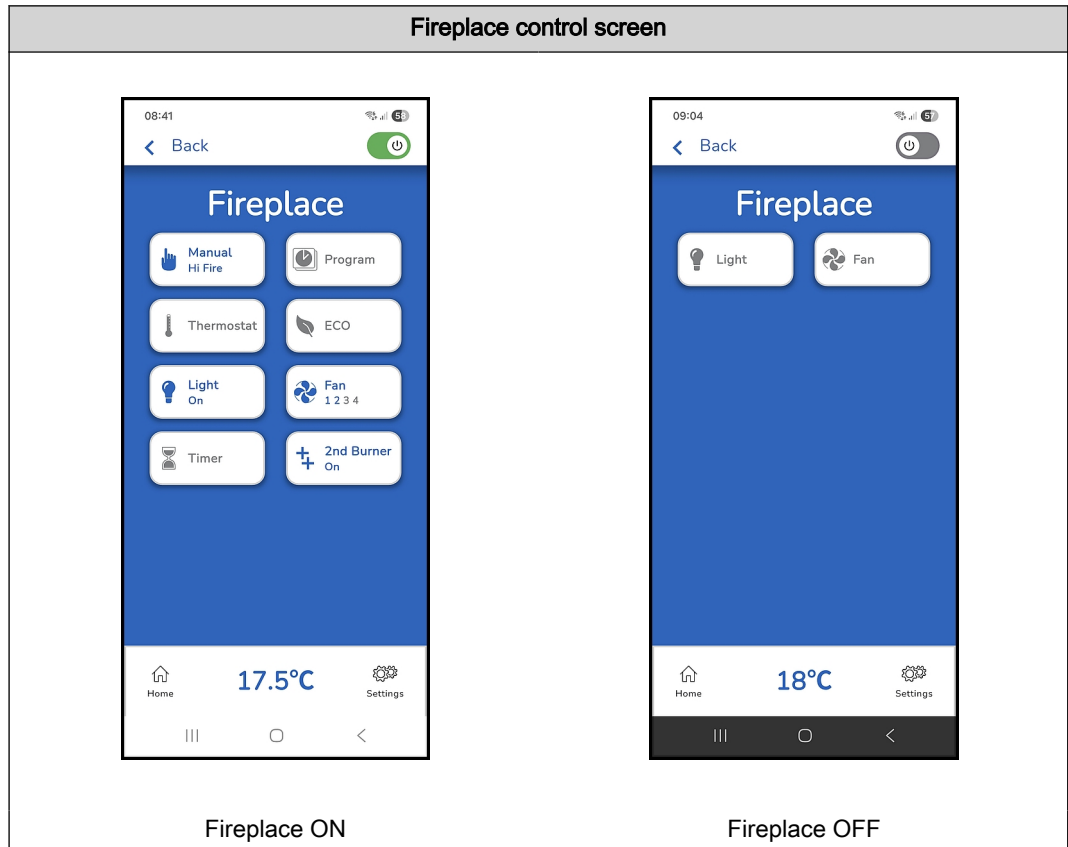

Control screen:

Access to some basic or activated functions. Activated functions are blue. Refer to section 6.5 for a description of the icons.

Room temperature:

Temperature of the room where the appliance is. The room temperature is measured with the handset and sent to the mobile device.

Note:

To save energy, the pilot-flame automatically extinguishes when the appliance is not used for a period of 5 days. To avoid this, make two automatic start-stop actions per week in program mode. See chapter 8.3.

8.1 ON / OFF

The ON / OFF function is on the Home screen and on the Control screen.

Home screen

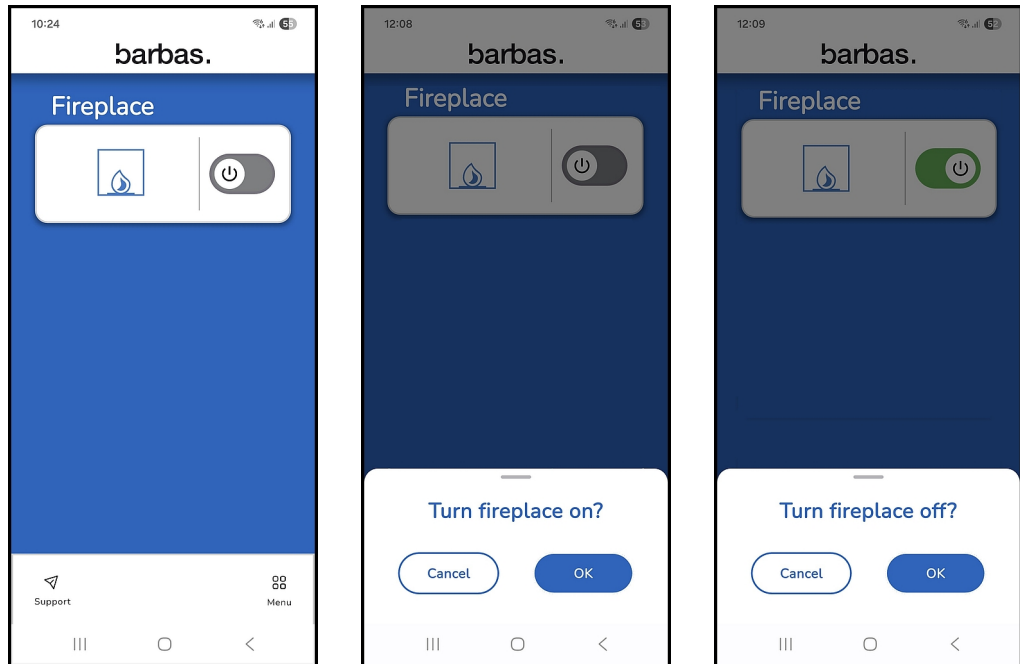

To start the fireplace

1. Go to Home screen
2. Slide "ON/OFF" button to right to turn ON fireplace.
3. Touch "OK" button for ignition.



Note: The total sequence from start to ignition of the burner will take about 20 seconds.



Note: The gas fireplace starts always at maximum heat input with all burners on.

To stop the fireplace

1. Go to Home screen
2. Slide "ON/OFF" button to left to turn OFF fireplace.
3. Touch "OK" button for stop.



Note: After switch to OFF of the fireplace, wait 30 seconds before the fireplace can be switched ON.

Control screen

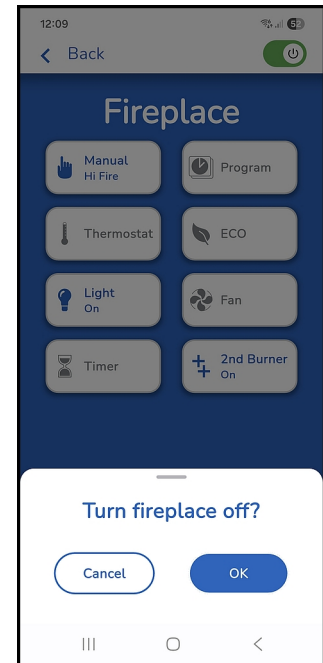
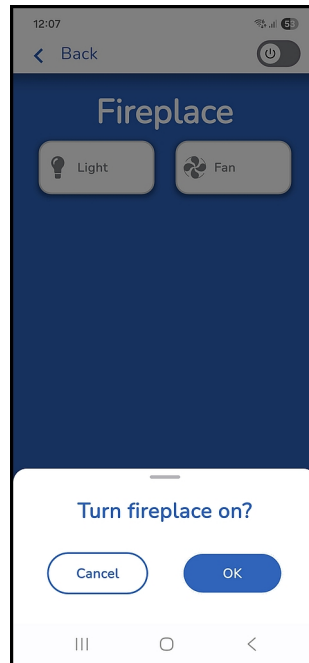

To start the fireplace

1. Go to Control screen
2. Slide "ON/OFF" button to right to turn ON fireplace.
3. Touch "OK" button for ignition.



Note: The total sequence from start to ignition of the burner will take about 20 seconds.



Note: The gas fireplace starts always at maximum heat input with all burners on.

To stop the fireplace

1. Go to Control screen
2. Slide "ON/OFF" button to left to turn OFF fireplace.
3. Touch "OK" button for stop.



Note: After switch to OFF of the fireplace, wait 30 seconds before the fireplace can be switched ON.

8.2 Manual mode

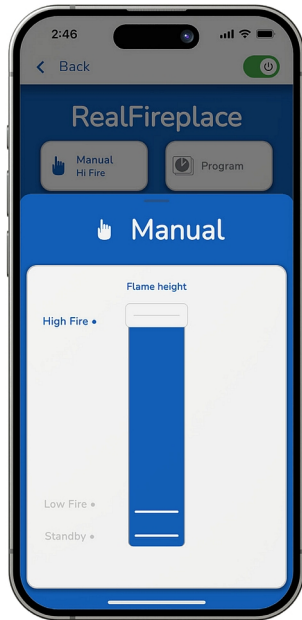

Manually increase or decrease the flame height.

1. tap the "Manual" icon.
2. move the slider up or down to adjust the flame height.



Note: For quick response, touch the font for "High Fire"; "Low Fire", or "Standby"

An activated Manual Mode shows a blue icon and the flame height is displayed as a percentage (%)

8.3 Program mode

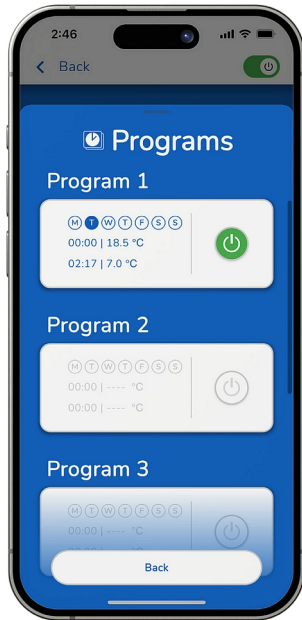

Save up to 8 programs to turn the fire on and off at specific times and days.



Note: The appliance must be ON to set or select a program mode.



Note: Before use of the Program mode make sure the time in the Barbas Wi-Fi Box 3 is synchronized with the time of the mobile device. Refer to section [7.12](#).

1. tap the "Program" icon
2. touch the "ON/OFF" button to select the desired program (1 - 8)
3. touch the desired Day button to select (M,T,W,T,F,S,S).
4. touch the Time "ON" or Time "OFF" buttons to scroll to desired times.
5. touch "Set" button to set desired times.
6. touch Temperature "ON" and/or Temperature "OFF" button to scroll to desired temperatures.
7. touch "Set" button to set desired temperatures.

An activated Program Mode shows a blue icon and with ON displayed.



Caution: If at any time when a program is active, the function manual mode, thermostat mode, ECO mode or timer is selected, the active program stops. To activate the program again, return to the function 'Program mode'.



Note: A yellow colored dot with an exclamation mark will be visible when two set programs overlap.

8.4 Thermostat mode

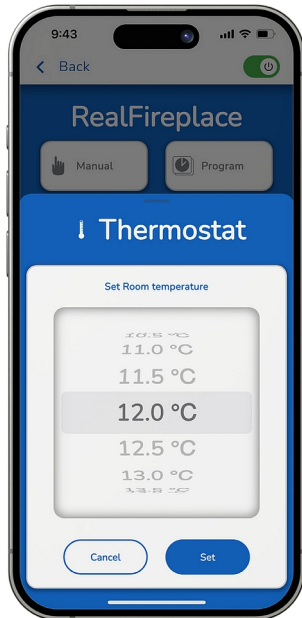

The fire automatically adjusts to maintain the set temperature in Thermostatic Mode.

1. tap the "Thermostat" icon
2. scroll to the desired room temperature setting and then touch the "Set" button.

An activated Thermostat Mode shows a blue icon and the set temperature.

8.5 ECO mode

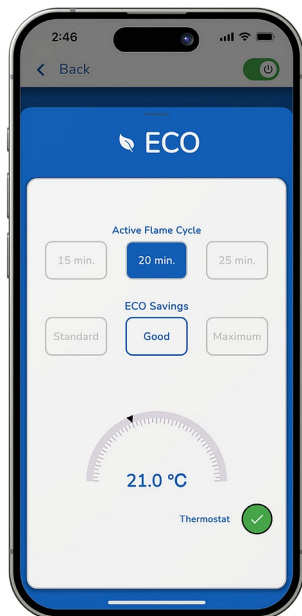

Save energy while enjoying a live flame picture.

1. tap the "ECO" icon.
2. select one of the three saving options; Standard [10%], Good [25%], or Maximum [45%]. The corresponding ECO efficiency percentage is displayed under the 180° arc.
3. select one of three Active Flame Cycle time options: 15 min., 20 min., or 25 min.



Note: A shorter Active Flame Cycle time results in greater live flame motion.

4. tap the Thermostat button to turn ON automatic ECO Mode.
5. use the slider arc to set the desired room temperature.



Note: In automatic ECO Mode the ECO-Savings percentage and Active Flame Cycle time correspond to hold the desired set temperature.

An activated ECO Mode shows a blue icon and current ECO settings.

8.6 Light

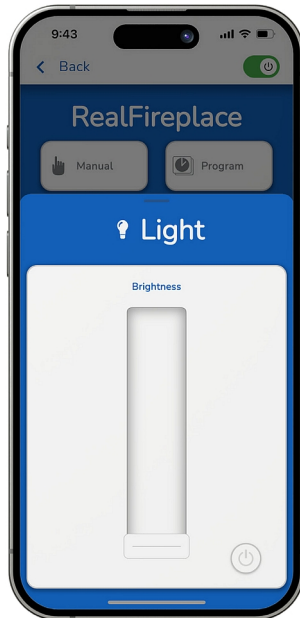

Adjust light brightness from 20% to 100%.

1. tap on the "Light" icon.
2. move the slider to increase or decrease the light intensity.
3. to switch off the light, press the ON/OFF button or pull the slider all the way down.



Note: The light functions independently of the gas control. The light automatically switches to the last set level when the fire is restarted.

An activated light mode shows a blue icon and with "ON" displayed.

8.7 Fan

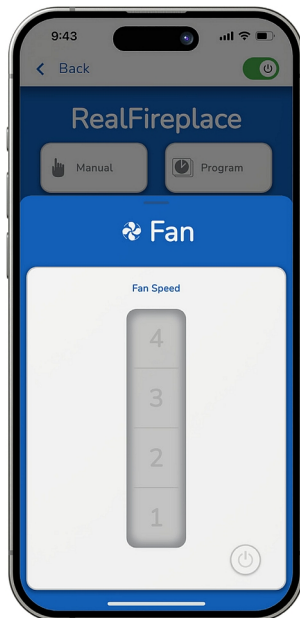

Note: The fan function is only available for Barbas gas fire places that are equipped with a circulation fan.



Note: The fan cannot be turned ON and OFF manually.

The circulation fan has 4 speed levels.

1. The circulation fan starts automatically approximately 4-5 minutes after the fireplace is turned on. The fan then runs at maximum speed (=setting 4) for a few seconds and then automatically switches to the set speed level (1, 2, 3, or 4).
2. Set the desired fan speed from low (1) to high (4).
3. Approximately 10 minutes after the fireplace is turned off, or set to standby mode only, the fan automatically switches off.

An active fan is indicated by a blue icon and the set speed level.

8.8 Timer

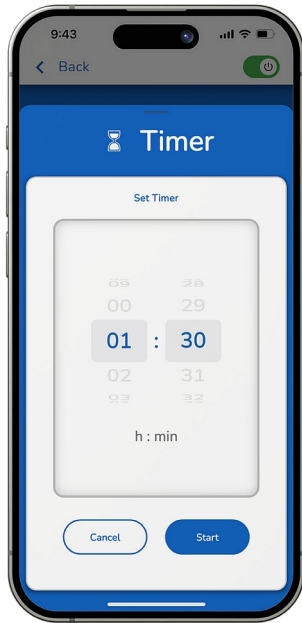

The Countdown Timer automatically turns the fire OFF after a set period of time. The maximum time duration is 9 hours and 59 minutes.

1. tap the "Timer" icon.
2. scroll to the desired hour and minute to set the fire OFF time.
3. touch the "Start" button to start the countdown timer.
4. to end the Countdown Timer, tap the "Timer" icon and press the "Stop" button.

An activated Countdown Timer shows a blue icon and the remaining countdown time.



Note: At the end of the set time duration the appliance is set to OFF (the pilot flame is also off). Set programs (see section 8.3) are no longer active. Go to the Home screen or Control screen to start the appliance again.

8.9 2nd burner

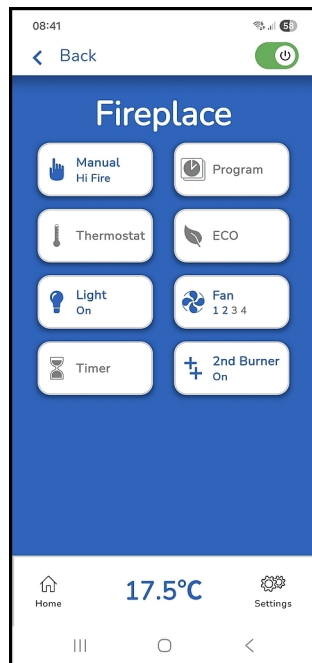

Turn ON and operate a second decorative burner.

1. to turn ON 2nd burner touch the "2nd burner" icon.
2. to turn OFF 2nd burner touch the "2nd burner" icon.

An activated 2nd burner shows a blue icon with "ON" displayed.

9 Support

Additional information can be found on the Home screen.

1. Touch "Support" button.
2. Touch "i" button to view information about all operating functions.
3. Touch "Contact" button for manufacturer details.

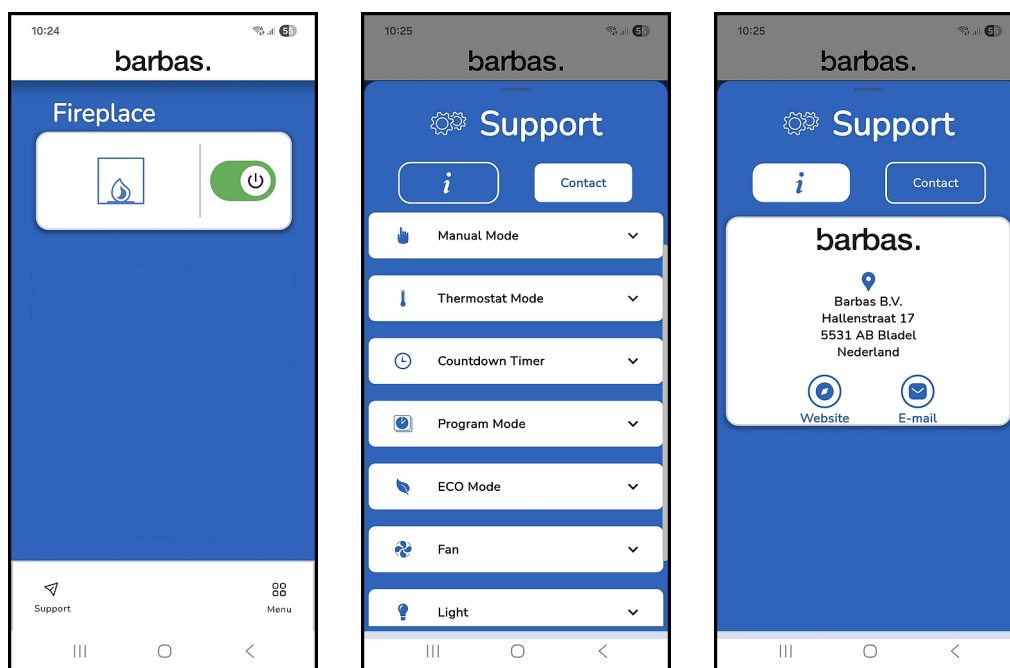

10 Frequent questions

- The Barbas Gas Fireplace App is compatible with Apple iOS and Google Android smart phones and tablets.
- The Barbas Gas Fireplace App can be installed on any number of smart devices.
- The Barbas Gas Fireplace App is stored locally on the smart device.
- The Barbas Gas Fireplace App does not work on PC or Mac computers.
- A Wi-Fi connection is necessary for the Barbas Gas Fireplace App to control the fireplace.
- The Barbas Gas Fireplace App can control up to 8 gas fireplaces. Each fireplace requires a separate Barbas Wi-Fi box.
- The Barbas Gas Fireplace App updates have no additional charge and are available via the Apple App Store or Google Play.
- New versions of the Barbas Gas Fireplace App are announced and available in the app store. You will be notified in the app itself of available updates.

11 Troubleshooting

11.1 Possible problems and solutions

Problem	Possible cause	Possible solution
The Barbas Wi-Fi Box 3 is not compatible.	Installation of the incorrect app.	Download and install the Barbas Gas Fireplace App.
The Barbas Wi-Fi Box 3 can not connect to the home network.	Bluetooth is not activated on the mobile device	Set Bluetooth ON in the settings of the mobile device
	The Wi-Fi router settings do not obey the requirements given in section 4.1.	Make sure the Wi-Fi router settings obey the requirements given in section 4.1.
	The Wi-Fi router changes automatically between the 2.4 GHz band and 5 GHz band or the Wi-Fi-router is set on the 5 GHz band.	<ol style="list-style-type: none"> 1. Set the Wi-Fi-router on the 2.4 GHz band. Refer to the manual of the router. 2. Switch off automatic change between frequencies. Refer to the manual of the router. 3. Press the reset button on the Barbas Wi-Fi Box 3 for 7 seconds (refer to sections 3.2 and 11.3). 4. Connect the Barbas Wi-Fi Box 3 with the Barbas Gas Fireplace App. Refer to section 7.
	The Barbas Wi-Fi Box 3 is not within reach of the Wi-Fi router.	Decrease the distance between the Barbas Wi-Fi Box 3 and the Wi-Fi router.
	Location access of the app is not allowed	Allow location access for the Barbas Gas Fireplace App in the settings of the mobile device.
The temperature indication on the Barbas Gas Fireplace App shows N/A.	Hand set is out of range of the appliance.	Make sure the hand set is near the appliance.
	Batteries in the hand set are empty.	Change the batteries of the hand set. Refer to the user manual of the appliance.
	Error in the receiver.	Press the reset button on the receiver until a one beep is heard. Refer to the user manual of the appliance.

Problem	Possible cause	Possible solution
A set program does not start and stop the appliance on the correct time.	The internal clock of the Barbas Wi-Fi Box 3 is not synchronized with the internal clock of the mobile device.	<ol style="list-style-type: none"> Go to the control screen of the appliance. Touch Settings button. Touch System information button. Touch "🕒" button to synchronize the date and clock time. The time synchronizes with the mobile device time.
The appliance sometimes does not react to the Barbas Wi-Fi Box 3.	Multiple users are on the same Wi-Fi channel.	Press the reset button on the Barbas Wi-Fi Box 3 for 1 second to change to another channel (refer to sections 3.2 and 11.3).
The functions Light, 2nd Burner, Timer, Fan (when present in the fireplace) are not visible	Functions are not selected in Settings menu	<ol style="list-style-type: none"> Go to the control screen of the appliance. Touch Settings button. Touch Feature Visibility button. Choose the applicable functions.
	Hand set is out of range of the appliance.	Make sure the hand set is near the appliance.
	Batteries in the hand set are empty.	Replace the batteries of the hand set. Refer to the user manual of the appliance.
Myfire_WiFi-Box network (only for Barbas Wi-Fi Box 1 and 2) is not in the list of available Wi-Fi networks.	Error in the Barbas Wi-Fi Box 1 / 2 .	<ol style="list-style-type: none"> Press the reset button on the Barbas Wi-Fi Box 1 / 2 for 7 seconds (refer to sections 3.2 and 11.3). stop and start the Barbas Gas Fireplace App and try to connect the Barbas Wi-Fi Box 3 again. <p>Contact your dealer if the problem stays.</p>



Note: When you contact your dealer, make sure you have photos available of the blue or white stickers on the Barbas Wi-Fi Box 3 and the receiver. Also, if applicable and possible, make screen shots of the error code that shows in the Barbas Gas Fireplace App or make a screen shot of the screen when the problem occurred.

11.2 Error codes

Error code	Message in Barbas Gas Fireplace App	Possible cause	Possible solution
F02	F02, contact service	<ul style="list-style-type: none"> The cam on the motor button is not making contact with the microswitch push button. Broken microswitch Wiring for the motor is broken. Reversed polarity microswitch Bent motor knob 	Make sure the motor knob and the microswitch on the gas control work properly. Replace any damaged parts.
F03	F03, contact service	<ul style="list-style-type: none"> Thermocouple wiring is incorrect Thermocouple wiring is not connected 	Make sure all thermocouple wires are connected properly.
F04	F04, ignition sequence malfunction. Wait 1 minute. Retry ignition. NOTE: After 3 failed ignition sequences, F06 is shown.	<ul style="list-style-type: none"> No gas supply Air in pilot supply line No spark 	Make sure the gas supply to the fireplace is correct. Make sure the ignition cable is connected properly to the pilot and gas control. Make sure the ignition cable is not damaged. Make sure the white ceramic housing of the ignition pin is not broken.
F05	F05, contact service	<ul style="list-style-type: none"> Not enough thermo-voltage Air in pilot supply line Low gas inlet pressure Bad thermocouple 	Make sure all thermocouple wires are connected properly. Make sure the gas supply to the fireplace is correct. Replace thermocouple.
F06	F06, contact service	<ul style="list-style-type: none"> No gas supply Air in pilot supply line No spark 	Make sure the gas supply to the fireplace is correct. Make sure the ignition cable is connected properly to the pilot and gas control. Make sure the ignition cable is not damaged. Make sure the white ceramic housing of the ignition pin is not broken.
F07	F07, replace handset batteries	<ul style="list-style-type: none"> Low battery power in handset 	Replace handset batteries
F08	F08, contact service	<ul style="list-style-type: none"> Low power supply to the receiver (by the light/fan module or by a mains adapter) 	Make sure the light/fan module (or mains adapter) works properly. Replace any damaged parts. (Remove the receiver batteries, when present)
F09	F09, (shown on handset only)	<ul style="list-style-type: none"> Receiver and handset are not synced 	Synchronize the receiver and handset as indicated in the appliance's installation manual.

Error code	Message in Barbas Gas Fireplace App	Possible cause	Possible solution
F12	F12, contact service	<ul style="list-style-type: none"> Receiver temperature exceeds 60°C. (Only when there are batteries in the receiver.) 	Remove the receiver batteries.
F13	F13, contact service	<ul style="list-style-type: none"> Receiver temperature exceeds 80°C. 	Make sure there is enough air circulation around the receiver. If necessary, protect the receiver with an additional heat shield.
F14	F14, contact service	<ul style="list-style-type: none"> Wrong receiver 	Make sure the right receiver is connected.
F16	F16, Handset out of range	<ul style="list-style-type: none"> Handset out of range for more than 1.5 h Electrical interference 	Make sure the handset is always in the same room as the gas fireplace. Make sure that other electrical appliances cannot affect the operation of the gas fireplace remote control.
F17	F17, contact service	<ul style="list-style-type: none"> Inlet voltage exceeds 7.25 V Malfunction of the light/fan module (or the mains adapter) 	Make sure the light/fan module (or mains adapter) works properly. Replace any damaged parts.
F18	F18, contact service	<ul style="list-style-type: none"> Switch panel/touch pad (option) is locked Short in cable or button 	Make sure the switch panel / touch pad works properly. Replace the switch panel / touch pad and cable when broken.
F19	F19, contact service	<ul style="list-style-type: none"> Insufficient thermo-voltage Thermocouple malfunction Low gas inlet pressure Improper thermocouple flame impingement Carbon build-up on thermocouple Gas control malfunction Resistance in thermocurrent circuit 	Make sure all thermocouple wires are connected properly. Make sure the gas supply to the fireplace is correct. Clean or replace thermocouple. Replace the gas control unit.
F26	F26, contact service	<ul style="list-style-type: none"> Receiver temperature exceeds 60°C. (Only when there are batteries in the receiver.) Receiver temperature exceeds 80°C. 	Remove the receiver batteries. Make sure there is enough air circulation around the receiver. If necessary, protect the receiver with an additional heat shield.

Error code	Message in Barbas Gas Fireplace App	Possible cause	Possible solution
F27	F27, contact service	<ul style="list-style-type: none"> Handset not connected with receiver for more than 3 hours. 	Put new batteries in the handset. Connect handset with receiver. Refer to the user manual of the appliance.
			Make sure the power supply to the receiver is correct. Connect handset with receiver. Refer to the user manual of the appliance.
F28	F28, on-demand pilot	<ul style="list-style-type: none"> Pilot flame goes off after 5 days, when during that complete period the pilot flame was on continuously, but the main burners were not operated. 	Start the appliance with the handset or the Barbas Gas Fireplace App.
F31	F31, contact service	<ul style="list-style-type: none"> General electronic error Connection cable from receiver to Wi-Fi box defective 	Press the reset button on the receiver until a beep is heard. (Refer to the user manual of the appliance). Contact your dealer if the problem stays.
F41	F41, check Wi-Fi	<ul style="list-style-type: none"> No power to the Barbas Wi-Fi Box 3 or to the Wi-Fi router. 	Make sure the power supply is correct.
		<ul style="list-style-type: none"> No Wi-Fi connection to the Barbas Wi-Fi Box 3 and/or mobile device. 	Make sure the mobile device is connected to the correct Wi-Fi home network.
			Make sure the Wi-Fi router settings obey the requirements given in section 4.1. Contact the supplier of the router if the problem stays.
F42	F42, check Wi-Fi Box	<ul style="list-style-type: none"> Router is off. 	Make sure the router is on.
		<ul style="list-style-type: none"> No connection between router and mobile phone or tablet. 	Make sure the mobile device can connect to a Wi-Fi network.
		<ul style="list-style-type: none"> Mobile device is not connected to the correct Wi-Fi home network. 	Make sure the mobile device is connected to the correct Wi-Fi home network.
		<ul style="list-style-type: none"> Router is communicating with another device. 	After a few seconds the error warning disappears, when the router is ready for communication with the Barbas Wi-Fi Box 3.

Error code	Message in Barbas Gas Fireplace App	Possible cause	Possible solution
F43	F43, No receiver connected, contact service	<ul style="list-style-type: none"> No communication between receiver and Barbas Wi-Fi Box 3. 	Contact your dealer.
F44	F44, contact service	<ul style="list-style-type: none"> Handset not within range of the receiver. 	Put handset near the appliance.
		<ul style="list-style-type: none"> Batteries in the handset are empty. 	Replace batteries.
		<ul style="list-style-type: none"> Error in the receiver. 	Press the reset button on the receiver until a one beep is heard. Refer to the user manual of the appliance.
F46	F46, (shown on handset only)	<ul style="list-style-type: none"> No or bad connection between Receiver and handset No power at Receiver (no power supply by the light/fan module) Low communication range (power supply by the light/fan module faulty, handset not communicating with Receiver) 	Make sure that the power supply from the light/fan module to the receiver is working properly. Make sure the batteries of the handset are in good condition.
F49	F49, contact service	<ul style="list-style-type: none"> Receiver software is not supported by Wi-Fi Box Version 2 	Replace the receiver with a new version.
F50	F50, contact service	<ul style="list-style-type: none"> Handset software is not supported by Wi-Fi Box Version 2 	Replace the handset with a new version.



Note: When you contact your dealer, make sure you have photos available of the blue or white stickers on the Barbas Wi-Fi Box 3 and the receiver. Also, if applicable and possible, make screen shots of the error code that shows in the Barbas Gas Fireplace App or make a screen shot of the screen when the problem occurred.

11.3 Reset of the Barbas Wi-Fi Box 3

Push the reset button on the Barbas Wi-Fi Box 3 with e.g. a paperclip.

Press reset button	LED	Function
Power ON or 1 second reset	LED 2 flashes red, green and blue	If no network is set, the AP Mode ¹⁾ activates for 2 hours. If the network is not set after 2 hours the AP mode goes to Standby Mode (LED 2 is off).
7 seconds (recommended)	LED 1 flashes every 0,5 second in blue	Removes the Wi-Fi settings and activates the AP mode ¹⁾ for 2 hours.
20 seconds	LED 1 flashes every 0,05 second in blue	Sets the Barbas Wi-Fi Box 3 back to factory settings and activates the AP mode ¹⁾ for 2 hours.

¹ Access Point mode: The Barbas Wi-Fi Box 3 recognizes a Wi-Fi network and is ready to connect with it.

12 Technical data

	Barbas Wi-Fi Box 3
Temperature range	0 °C - 80 °C
Radio frequency	2.4 GHz
Power supply	230 VAC / 6 VDC
Wireless communication	<ul style="list-style-type: none">• WPA2 authentication• AES 256-bit encryption security• Compatible with IEEE 801.11 b/g/n• Bluetooth LE v5.0 Class 1
Power consumption	<ul style="list-style-type: none">• Nominal: max 0.5 W• Standby: max 5 mA

13 Warranty Terms

To make a claim under the warranty, it is important to register the Barbas appliance after purchase via www.barbas.com.

Barbas Warranty Terms

Barbas B.V. guarantees the quality of the supplied Barbas appliance and the quality of the materials used. All Barbas appliances are developed and manufactured according to the highest possible quality standards. If, despite all this, something should prove amiss with the Barbas appliance you have purchased, Barbas B.V. offers the following manufacturer's warranty.

Article 1: Warranty

1. If Barbas B.V. determines that the Barbas appliance you have purchased is defective as a result of a flaw in the construction or material, Barbas B.V. guarantees to repair or replace the appliance free of charge, without charging any costs for labor or spare parts.
2. Repair or replacement of the Barbas appliance will be undertaken by Barbas B.V. or by a Barbas dealer as designated by Barbas B.V.
3. This warranty is supplementary to the existing legal national warranty of Barbas dealers and Barbas B.V. in the country of purchase and is not intended to restrict your rights and claims based on the applicable legal provisions.

Article 2: Warranty conditions

1. Should you wish to claim under the warranty, please contact your Barbas dealer.
2. Complaints should be reported as quickly as possible after they have manifested themselves.
3. Complaints will only be accepted if they are reported to the Barbas dealer, together with the serial number of the Barbas appliance which is stated on the enclosed documents.
4. In addition, the original receipt (invoice, receipt, cash receipt) showing the date of purchase must also be submitted.
5. Repairs and replacements during the warranty period do not give any entitlement to an extension of the warranty period. After a repair or replacement of warranty parts, the warranty period shall be deemed to have started on the date of purchasing the Barbas appliance.
6. If a certain part is eligible for the warranty and the original part is no longer available, Barbas B.V. shall ensure that an alternative part of at least the same quality shall be provided.

Article 3: Warranty exclusions

1. The warranty on the Barbas appliance ceases to be in effect if:
 - a. it is not installed according to the installation instructions, and to national and/or local regulations;
 - b. it has been installed, connected or repaired by a non-Barbas dealer;
 - c. it has not be used or maintained according to the instructions for use;

- d. it has been changed, neglected or roughly treated;
- e. it has been damaged as a result of external causes (outside the appliance itself), for example, lightning strike, water damage or fire;
2. In addition, the warranty lapses if the original purchase receipt shows any change, deletion, removal or if it is illegible.

Article 4: Warranty area

1. The warranty is only valid in those countries where Barbas appliances are sold through an official dealer network.

Article 5: Warranty period

1. This warranty will only be granted during the warranty period.
2. The body of the Barbas appliance is guaranteed for a period of 10 years against construction and/or material faults, starting from the moment of purchase.
3. For other parts of the Barbas appliance, a similar warranty applies from the moment of purchase for a period of two years.
4. For user parts such as glass, glass sealing cord and the interior of the combustion chamber, a similar guarantee is given until after the first burning.

Article 6: Liability

1. A claim granted by Barbas B.V. under this warranty does not automatically imply that Barbas B.V. also accepts liability for any possible damage. The liability of Barbas B.V. never extends further than that stated in these warranty conditions. Any liability of Barbas B.V. for consequential damage is expressly excluded.
2. That stated in this provision is not valid if and to the extent that it derives from a mandatory provision.
3. All agreements entered into by Barbas B.V. are, unless specifically stated otherwise in writing and to the extent that they are permitted based on applicable law, subject to the FME-CWM general sales and delivery conditions for the technology industry.

Barbas B.V.
Hallenstraat 17
5531 AB Bladel
The Netherlands

Email: info@Barbas.com

Carefully retain the enclosed documents; they show the serial number of the appliance. You will need this if you wish to claim under the warranty.

barbas .

Your Barbas dealer